

Unidrive M100 to M400 Size 3 UL Conduit Box Installation Sheet

1 Safety information



Follow the instructions

The mechanical and electrical installation instructions must be adhered to. Any questions or doubt should be referred to the supplier of the equipment. It is the responsibility of the owner or user to ensure that the installation of the drive and any external option unit, and the way in which they are operated and maintained, comply with any applicable legislation, regulation, and code of practice in the country in which the equipment is used.



Competence of the installer

The drive must be installed by qualified personnel who are familiar with the requirements for safety and EMC. The installer is responsible for ensuring that the end product or system complies with all the relevant laws in the country where it is to be used.

2 Introduction

This document covers the UL conduit box mounting instructions for Unidrive M100 to M400, frame size 3 drives and derivatives.

When fitted, the drive meets the requirement for Type 1 protection according to UL50 and UL50E.

Type 1 enclosures are intended for indoor use only. They provide a degree of protection to personnel against incidental contact with the enclosed equipment and a degree of protection against falling debris.

The following items are supplied in the kit:

Table 2-1 Contents of the kit (CT part number: 3470-0098)

Description	Image	Qty
Conduit box		x 1
Conduit cover		x 1
Grounding clamp		x 3
M4 x 16 torx taptite screw		x 7
UL conduit box installation sheet		x 1

The installed conduit kit does not change the width or depth of the drive. However, this conduit kit will add 103 mm (4.0 in) to the height of the drive.

Table 2-2 shows the combined drive and conduit box dimensions.

Table 2-2 Dimensions

Frame size	H		W		D	
	mm	in	mm	in	mm	in
3	314	12.4	90	3.5	160	6.3

3 Installation



Stored charge

The drive contains capacitors that remain charged to a potentially lethal voltage after the AC and / or DC power supply has been disconnected. If the drive has been energized, the power supply must be isolated at least ten minutes before work may continue.

Normally, the capacitors are discharged by an internal resistor. Under certain, unusual fault conditions, it is possible that the capacitors may fail to discharge, or be prevented from being discharged by a voltage applied to the output terminals. If the drive has failed in a manner that causes the display to go blank immediately, it is possible the capacitors will not be discharged. In this case, consult Control Techniques or their authorized distributor.

Figure 3-1 Removing the drive terminal cover

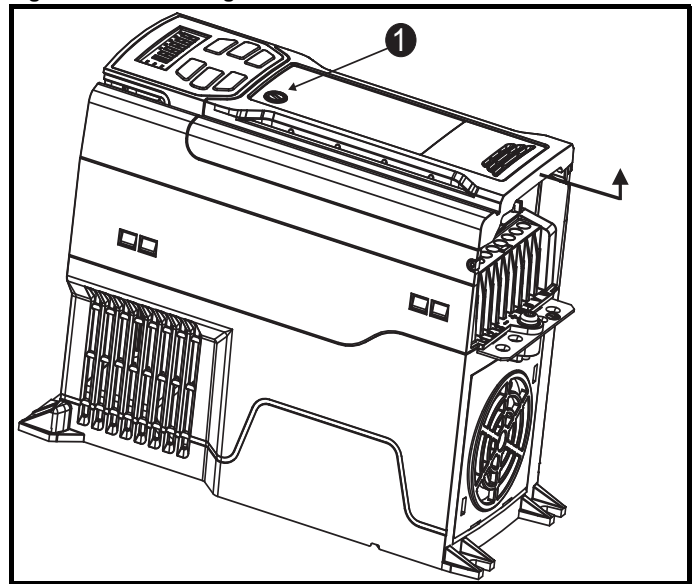

Use flat blade screwdriver to remove the drive terminal cover by turning the cover release 30° counter clockwise and sliding the cover downward (1).



0478-0383-01

Figure 3-2 Holes for conduit fittings

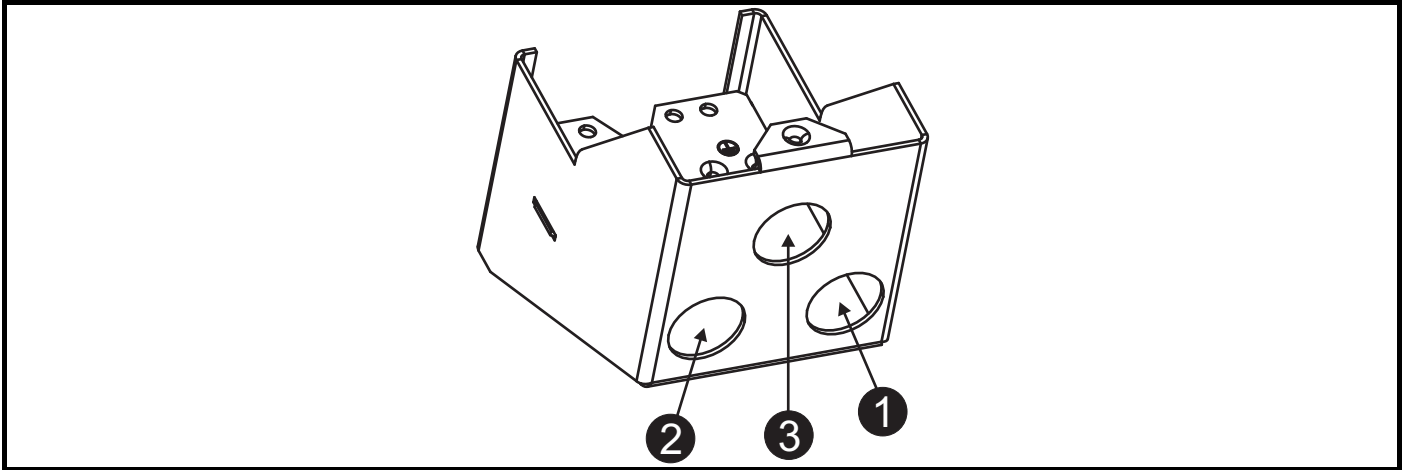

- Using the pilot holes provided on the bottom of the conduit box, drill holes for appropriately sized conduit fittings. Motor cables with motor ground wire (1), supply cables with supply ground wire (2), and control/communication cables (if applicable) (3) need to be run in separate conduits.

Figure 3-3 Installation of conduit connection box

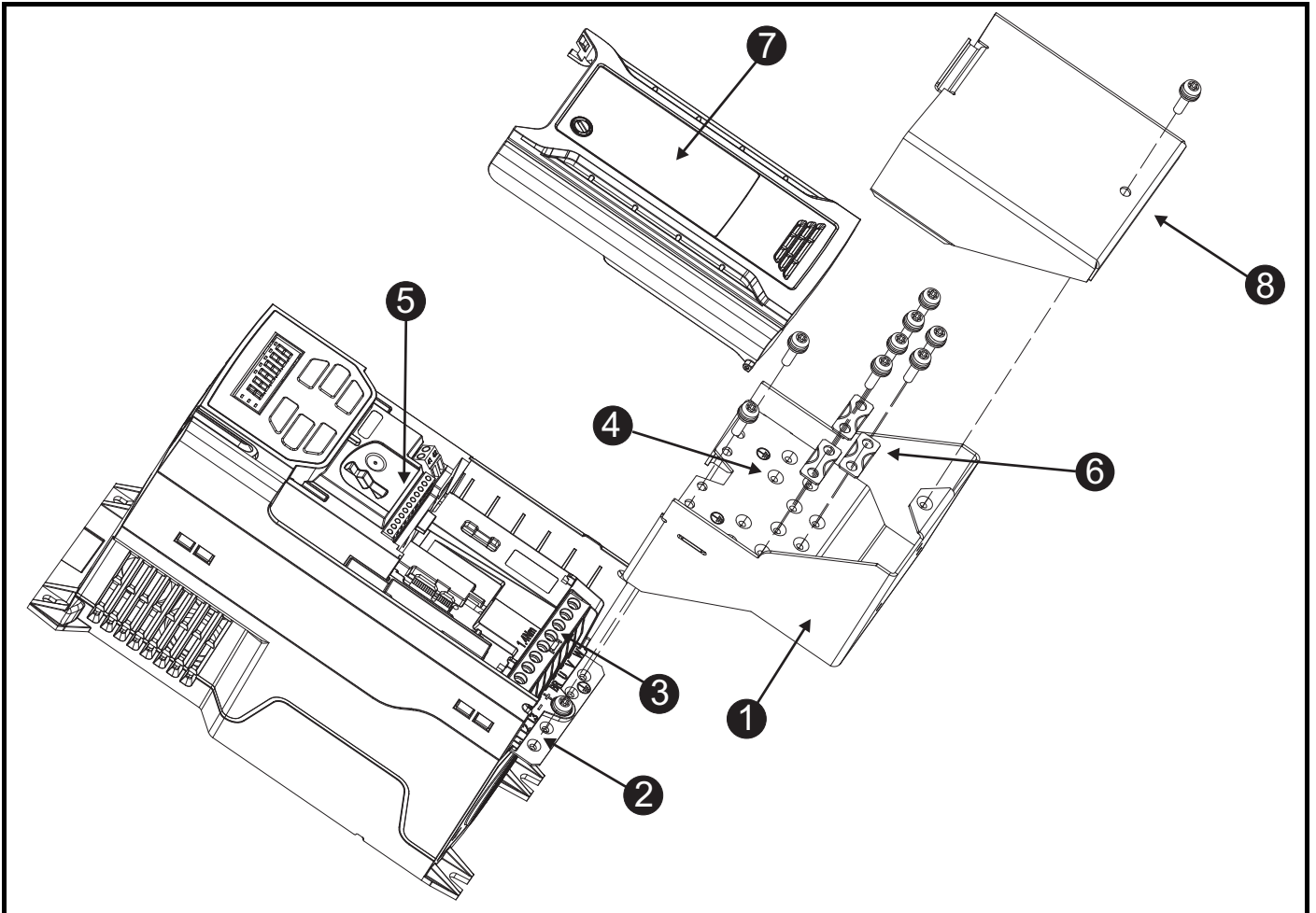

- Attach the conduit box (1) to the grounding bar (2) using the four M4 x 8 screws provided with the drive. Maximum recommended torque is 1.5 N m (13 lb in).
- Attach the conduit fittings to the conduit box holes; run the conduit to the drive.
- Run the motor cables (U,V, W) and motor ground wire through the back-right conduit. Connect the wires to the motor connector (U,V,W) (3). Maximum recommended torque for screw terminals is 1.4 N m (12 lb in).
- Run the supply cables (L1,L2,L3) and supply ground wire through the back-left conduit. Connect the wires to the supply connector (L1,L2,L3) (3). Maximum recommended torque for screw terminals is 1.4 N m (12 lb in).
- Fasten M4 ring terminals, suitable for the wire size, to the supply ground and motor ground wires. Connect the ground wires to the conduit box grounding locations using M4 x 16 screws (4). Maximum recommended torque is 1.5 N m (13 lb in).
- Run the control cables through the front-center conduit. Connect the control cables to the control connector as required (5). Maximum recommended torque for control terminals is 0.2 N m (2 lb in).
- Secure all cables and cable shielding to the conduit box using the grounding clamps and M4 x 16 screws (6). Maximum recommended torque is 1.5 N m (13 lb in).
- Replace the drive terminal cover by laying it on the drive and sliding it upward (7).
- Attach the conduit box cover to the conduit box using the M4 x 16 screw (8). Maximum recommended torque is 1.5 N m (13 lb in).



0478-0383-01