

Dupline® Car Park System

Type GP 6540 3421

Ultrasonic Sensor without LED Indication



- Ultrasonic sensor for detection of cars
- Low current consumption
- Self-calibration of the sensor can be performed globally on all sensors or locally on a single sensor
- Wide measuring range
- Protected against dust and moisture
- Dupline® 3-wire system with power
- Address coding with GAP 1605
- Possibility to connect passive external LED indicators

Product Description

The ultrasonic sensor is part of the car park system which contains other variants of sensors, passive displays and direction indicators.

The GP 6540 3421 sensor is installed in the middle of the ceiling above the parking bay and detects whether a car is parked in the bay. The sensor, which does not have LED-signalling built in, is connected to a passive LED-unit located outside the parking bay, via a 5 pin connector. The parking bay status is there indicated using the LEDs.

The GP 6540 3421 sensor can use up to 4 I/O's (see under general specifications). If the lowest amount of I/O's are used, it is possible to have 123 sensors, and one Direction indicator for each Dupline Master Module. Up to 16 Dupline Master Modules can be connected using a multidrop cable. This means that 1,968 sensors can be connected in a network to a PC via RS485/RS232.

Ordering key

GP 6540 3421

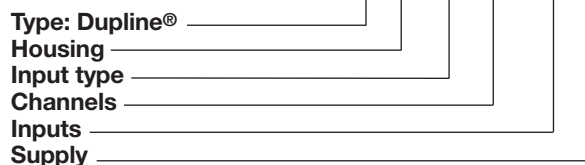

Type Selection

GP 6540 3421 Sensor without LED indication

Input/Output Specifications

6-pin connector

- Pin 1 + 2: 24 VDC supply
- Pin 3 + 4: Gnd. minus supply or Dupline® minus
- Pin 5 + 6: Dupline® plus connection

5-pin connector

- Pin 1: Com = 24 VDC supply
- Pin 2: Red
- Pin 3: Not in use
- Pin 4: BL1 } Green or blue
- Pin 5: BL2 }

RJ45 connector for address programming with GAP 1605

Supply Specifications

Power supply	24 VDC min.; 32 VDC max. (Overvoltage category III (IEC60664))
Consumption on the Dupline bus	0.4 mA
Max. supply current	10 mA

General Specifications

Ultrasonic frequency:	40 kHz
Max. distance between ceiling and floor:	3.5 m
Min. distance between ceiling and floor:	2.0 m
Minimum calibration distance:	2 m
LED indication:	No LED's
The sensor uses 4 I/O's and can be programmed as:	
• I/O 1 (Input)	input signal which indicates the status of the parking bay
• I/O 5 (Output)	output signal for reservation of the parking bay
• I/O 6: (Output)	Sync. signal: This I/O must be programmed with the Dupline addresses P5 or P6
• I/O 7: (Output)	for common sensor calibration command of all sensors

Mode of Operation

To avoid a weak signal, the sensor must be installed pointing directly at a hard surface, as for instance concrete. A soft or uneven surface will reduce the signal.

The ceramic sensor emits a signal at a frequency of 40 Hz which is reflected and returned to the sensor. The reflected signal indicates whether the parking bay is available or occupied.

When a car enters the parking bay and I/O 1 on the sensor detects the presence of the car for more than 8 seconds, the LEDs on the GP6589010x indicate red for

occupied, and simultaneously, a signal is sent to the central unit via a dedicated address on the Dupline bus. The sensor will not react to objects lower than 0,8 m.

Hint:
 I/O 1 indicates the presence of a car. It is recommended, if the system use the reservation feature as well, to use the same Dupline address on both I/O 1 and I/O 5. In that way, the installer uses less addresses.

The sensors have a built-in anti-reflection feature that keeps them from interrupting each other. To activate this

feature and thereby ensure a correct operating sensor, a synchronization address must be entered on I/O 6 of each sensor. The selected address must be either P5 or P6. Two neighbour sensors are not allowed to use the same synchronization address, so on a line of sensors the synchronization addresses must be changing between P5 and P6 (P5, P6, P5, P6, P5.....)

The Master module used for generating the bus carrier signal must be type GP34960005700, because this unit sends out the synchronization signals to the sensors.

Please note that apart from addresses P5 and P6, also P7 and P8 are reserved and cannot be used for sending the sensor status signal.

I/O 7 is for sensor calibration. It is recommended to use the same Dupline address on all the installed sensors. The installer uses less addresses and it is possible to make a global calibration on all the sensors at the same time.

When a car leaves the parking bay, the sensor will continue being red for 8 seconds before turning into green/blue.

The sensor is designed to work in an area which is:

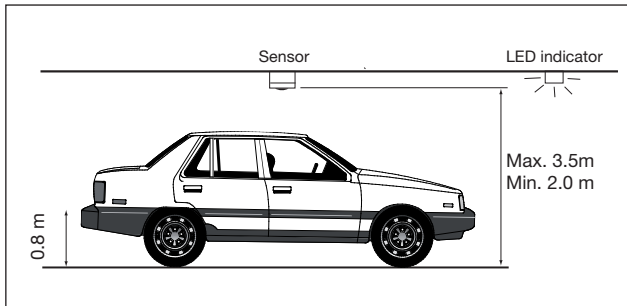

The sensor should be placed freely, e.g. in the following way:

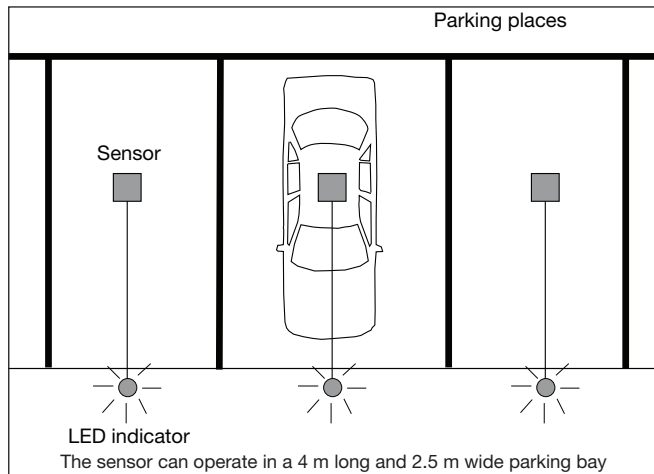
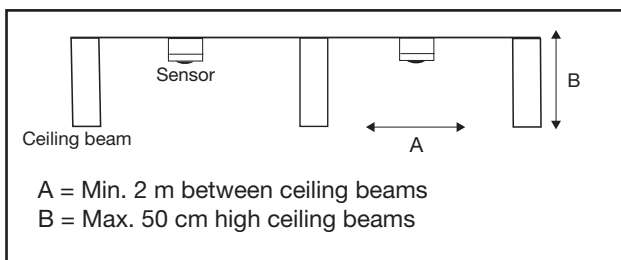

Calibration

The sensor is self-calibrating. It is important to perform the calibration when the parking bay is empty.

There are two ways of calibrating a sensor .

Manual calibration is a local calibration of the single sensor.

- Push the button inside the sensor and close the sensor.
- The LED on the GP6589010x flashes green/blue for 30 seconds with 2 Hz.

(The electrician has time to get clear of the sensor before the calibration starts).

- The calibration starts when the LED on the GP6589010x flashes green/blue for 16 seconds with 4 Hz.
- If the calibration is OK, the LED on the GP6589010x will respond with a constant green/blue light.
- If the calibration fails, the LED on the GP6589010x will respond with a constant red light.
- If the LED on the

GP6589010x flashes red during the calibration, the sensor is out of range. Adjust the sensor into the sensing area and recalibrate the sensor.

Automatic calibration with the GTU8 is a global calibration of all connected sensors. The parking bay must be empty during the calibration process.

- Select "sensor calibration" under "mode" on the GTU8.
- The GTU8 performs an

automatic calibration of the connected sensors.

- The automatic calibration is equal to the manual calibration except for the 30 seconds of delay before starting calibration.

Before starting the global calibration process, the Dupline address, which is being used as a common calibration address, must be selected. The calibration signal is performed as a sequence that prevents noise or unmotivated activation of the calibration process.

Environment

- Protection: IP 61
- Operating temperature: -25°C to 70°C
- Storage temperature: -40°C to 85°C
- Pollution Degree: 3 (IEC 60664)
- Dimensions: 85 x 85 x 80 mm
- Material: The case is made of polypropylene. The sensor lid is made of clear Polycarbonate.

Switch Box Dimensions

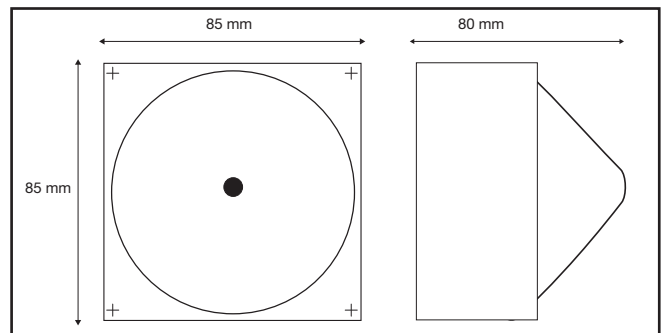

System Diagram

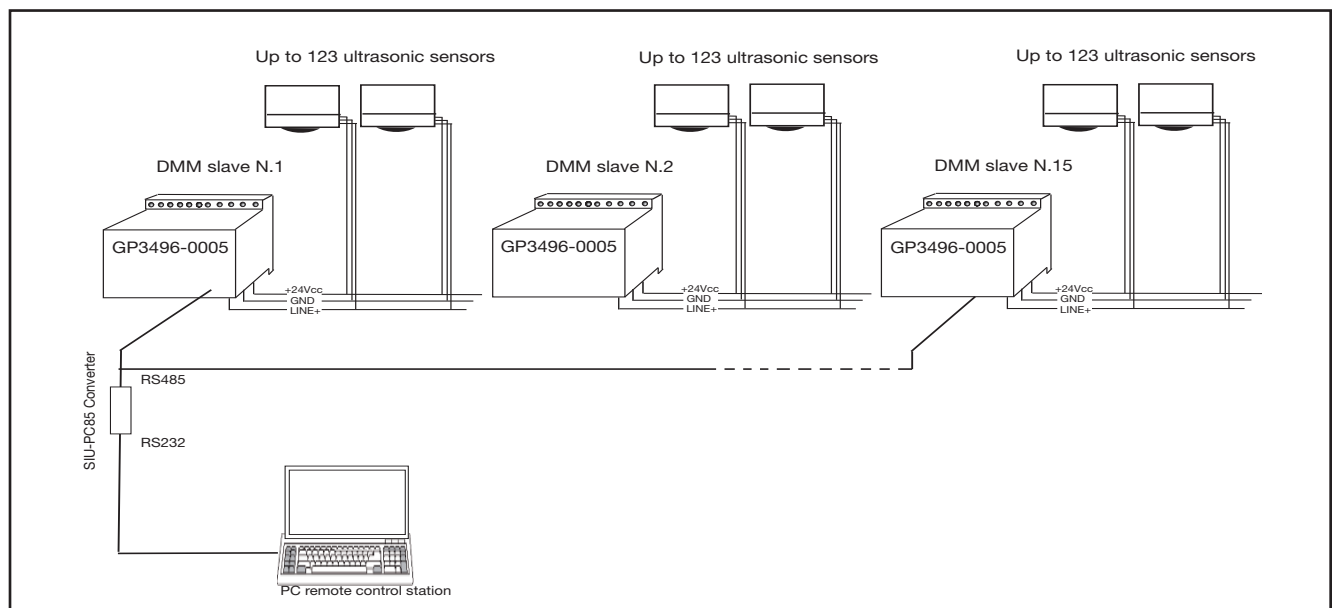

Example of a Connection

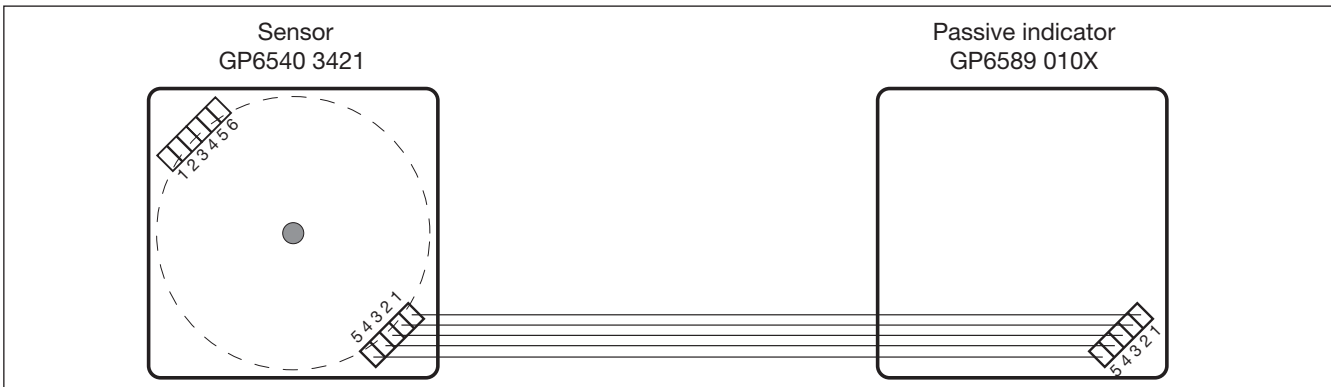

Example of a Slave System

Example of a system with two sensors, one indicator and one display (no external PC).

The indicator must be set up as “Slave” using switches. See the indicator data sheet or manual for more detailed instructions. The indicator is programmed using GAP 1605. I/O 1 and 5 are programmed using “A1” (start marker). I/O 2 and 6 are programmed using “A4” (end marker). The I/O1 on the sensors are addressed “A2” and “A3” respectively, using GAP

1605. The indicator now automatically knows which sensors to detect, because it looks at all addresses between the start and end markers.

This means that many indicators can be present on the same Dupline network.

I/O 6 on sensor #1 must be programmed with P5, and I/O6 on sensor #2 must be programmed with P6. The indicator uses the display as a monitor during the programming. See the indicator data sheet or manual for more detailed instructions.

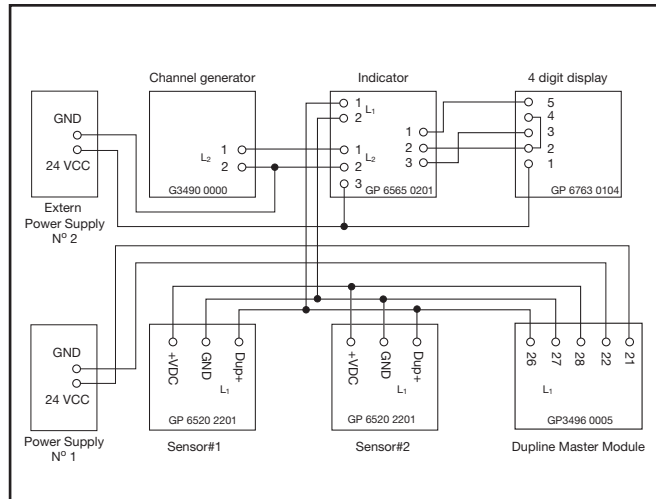

PCB View

