

Dupline® Plug & Play Master Module Interface for GE-Fanuc PLC Type G 3496 0002



- GE-Fanuc master
- Plug and play: Automatic communication with specific PLC/Controllers
- Built-in normal Dupline® Channel Generator
- 128 I/O's and DC power supply on 3 wires
- RS232/RS422/RS485 port for interfacing to control system
- Split-I/O mode selectable (128 inputs and 128 outputs)
- LED-indications for supply, Dupline carrier and Com-port TX
- Galvanically isolated Com-port supplied by internal DC/DC converter

Product Description

G 3496 0002 is designed as a cost-effective solution for interfacing Dupline® I/O's to a GE-Fanuc PLC. It performs three functions: Dupline®

channel generator, power supply synchronization (enables 3-wire system with supply) and RS232/RS422/RS485 interface.

Ordering Key

G 3496 0002 700

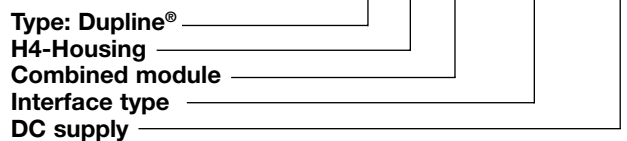

Type Selection

Supply	PLC Interface Conformance	Ordering no.
20-30 VDC	GE-Fanuc Micro 90 & 90-30	G 3496 0002 700

Input/Output Specifications

Power output	
Output voltage	20-30 VDC (pulsating)
Output current	< 3.0 A @ 50°C
Short circuit protection	4 A quick acting fuse
Output voltage drop	< 1.0 V
Dupline® carrier	
Output voltage	8.2 V (pulsating)
Current	< 60 mA
Short circuit protection	Yes
Scan time	
128 channels	132.2 ms
64 channels	69.8 ms
Communication port	
Standard	RS232/RS422/RS485
Split I/O mode	Yes, selectable
Normal Dupline mode	Yes, selectable
Connection	9 pole female Sub-D
Dielectric voltage	
Com-port Dupline®	1 kVAC (rms)
Protocol	SNP / Modbus-RTU (Function code 01 & 15)
Baud rate	19200 (9600 for Modbus-RTU protocol)
Data bits	8
Start bit	1
Stop bit	1
Parity	Odd
Flow-control	None

Input/Output Specifications (Cont.)

Pin assignment	
2-wire RS 485	
S/R Data line + (B)	Pin 3
S/R Data line - (A)	Pin 8
GND	Pin 5
4-wire RS 485/RS 422	
R Data line + (B)	Pin 3
R Data line - (A)	Pin 8
S Data line + (B)	Pin 2
S Data line - (A)	Pin 7
Direction	Pin 4
	(Connect to GND pin 5 when using 4-wire communication)
RS 232	
TX	Pin 1
RX	Pin 9
GND	Pin 5

Supply Specifications

Power supply	
Operational voltage (V _{in})	Overvoltage cat. III (IEC 60664) 20-30 VDC
Reverse polarity protection	None
Current consumption	< 150 mA + Power load
Power dissipation	< 5 W
Transient protection voltage	800 V
Dielectric voltage	
Supply - Dupline®	None
Supply - com-port	1 kVAC (rms)

General Specifications

Power ON delay	2 s	Humidity (non-condensing)	20 to 80%
Indication for		Mechanical resistance	
Com-port Tx	LED, red	Shock	15 G (11 ms)
Supply ON	LED, green	Vibration	2 G (6 to 55 Hz)
Dupline® carrier	LED, yellow	Dimensions	H4-Housing
Environment		Material	(see Technical information)
Pollution degree	3 (IEC 60664)	Weight	100 g
Operating temperature	0° to +50°C (+32° to +122°F)		
Storage temperature	-50° to +85°C (-58° to +185°F)		

Mode of Operation

The Dupline® Master Module (DMM) controls a 3-wire bus with signal, DC-power and common GND. The DMM is connected to a standard DC-supply, which it synchronizes with the Dupline® carrier signal before it is output to supply. The synchronization is necessary in order to enable the Dupline® and DC-supply to share the GND-wire.

The Dupline® Master Module is a Dupline® Channel Generator with the function of a master.

This means that the 128 Dupline® I/O's will be read/written by the DMM and then sent to the PLC.

The DMM can run in two different modes – Normal mode and split I/O mode. In Normal mode, Dupline® operates as a peer-to-peer system, where the channel generator automatically establishes a connection between Dupline® inputs and Dupline® outputs which are coded to the same Dupline® address. If e.g. an

input coded for B5 is activated, the output(s) coded for B5 will also be activated.

Consequently, a Dupline®-output can either be activated through the output-data received on DMM or by an active Dupline® input coded for the same Dupline®-address. In "Split I/O" mode, the channel generator treats the Dupline® inputs and Dupline® outputs independently. If e.g. an input coded for B5 is activated, the DMM

will make the information available for the PLC (like in normal mode), but it will not automatically activate the Dupline® output(s) coded to B5. The Dupline® outputs are controlled exclusively through the output data received from the PLC. In this mode, up to 128 Dupline® inputs and 128 Dupline® outputs are available, since an input and an output coded to the same Dupline® address can operate independently.

Dip-Switch Setting

- Sw.2 On:** High PLC-memory Add, i.e. all address numbers are increased by 256. This setting is only used when two DMM are connected to the same PLC.
- Sw.2 Off:**
- Sw.3 On:** Modbus-RTU Mode
- Sw.3 Off:** SNP Mode
- Sw.4 On:** Split I/O Channel Generator Mode (See "Mode of Operation")
- Sw.4 Off:** Normal Dupline® Monostable Channel Generator Mode
- Sw.5 On:** 64 Dupline® channels
- Sw.5 Off:** 128 Dupline® channels

Memory Mapping

Table of the memory mapping to the PLC

Dupline® Channel	GE-Fanuc		Dupline® Channel	GE-Fanuc	
	Read	Write		Read	Write
A1	Q0257	Q0385	E1	Q0289	Q0417
A2	Q0258	Q0386	F1	Q0297	Q0425
A3	Q0259	Q0387	G1	Q0305	Q0433
A4	Q0260	Q0388	H1	Q0313	Q0441
A5	Q0261	Q0389	I1	Q0321	Q0449
A6	Q0262	Q0390	J1	Q0329	Q0457
A7	Q0263	Q0391	K1	Q0337	Q0465
A8	Q0264	Q0392	L1	Q0345	Q0473
B1	Q0265	Q0393	M1	Q0353	Q0481
B8	Q0272	Q0400	N1	Q0361	Q0489
C1	Q0273	Q0401	O1	Q0369	Q0497
D1	Q0281	Q0409	P1	Q0377	Q0505

Wiring Diagram

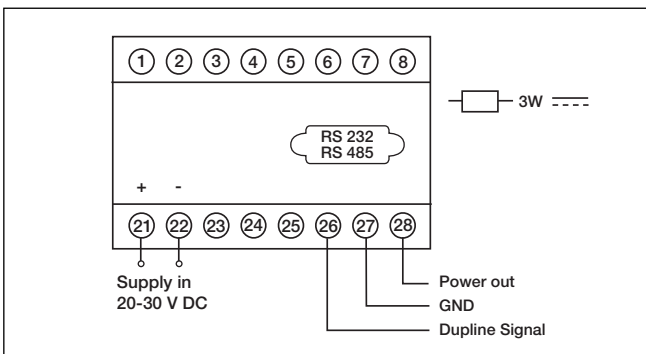

Pin Assignment

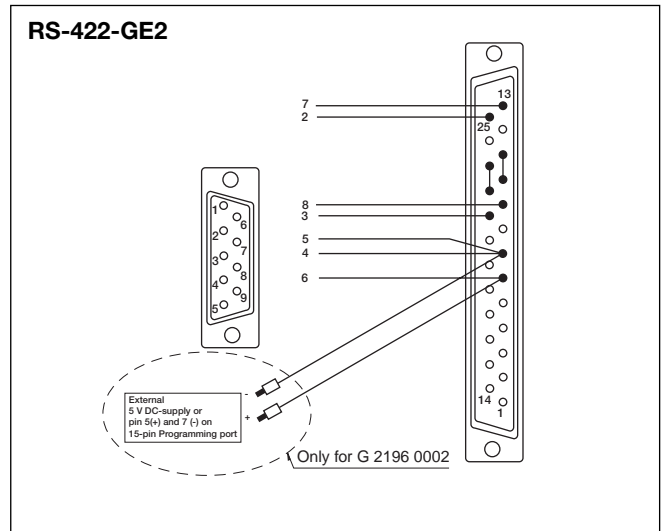
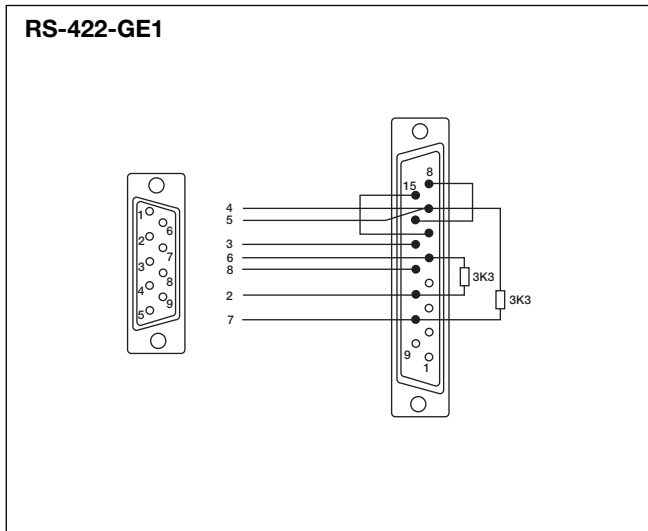

Accessories

GE-Fanuc 90-30 / 90 Micro Cable Sub-D 9M/15M for 15p Programming port	RS-422-GE1
GE-Fanuc CMM311 Cable Sub-D 9M/25M for 25p Communication port	RS-422-GE2

Additional Information

Scope of supply 1 x Master Module	G3496 0002 700
---	----------------

Installation Hints

Interfacing to GE-Fanuc 90-30 PLC's directly on the programming-port (Switch 3 OFF & switch 2 OFF)

Interfacing to GE-Fanuc 90-30 PLC's – CPU type 331 or higher, equipped with communication coprocessor module CMM 311 in Modbus-RTU mode (Switch 3 ON & switch 2 OFF)

Interfacing to GE-Fanuc 90-30 PLC's – CPU type 350 or higher, equipped with communication coprocessor module CMM 311 in Modbus-RTU mode (Switch 3 ON & switch 2 ON)

No TX-LED

Configuration fault	Check Dip-Switches check configuration in PLC
Hardware fault	Check the wiring.
No Dupline® Carrier-LED	
Short circuit	Short circuit between the two Dupline® wires.